

Container Supply Company

12571 Western Avenue
Garden Grove, CA 92841

(714)892-8321

FAX (714)892-3824

www.containersupplycompany.com

3 Gallon Pail with Ears

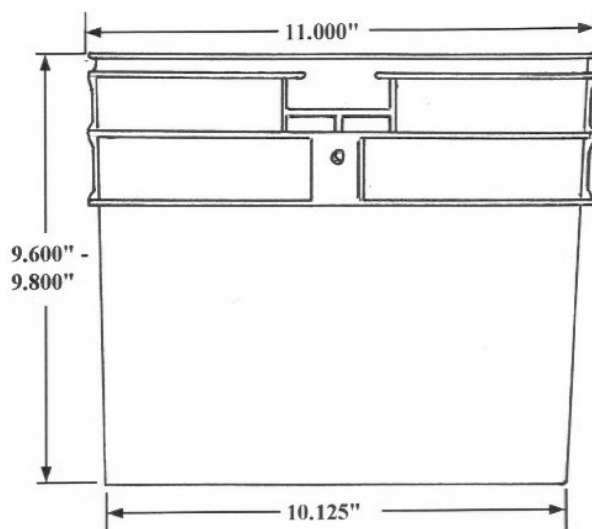

3 Gallon Round Plastic Pail Specifications

3 Gallon Pail Weight (Empty):

460 to 495 grams

3 Gallon Cover Weight (Alone):

Regular Cover = 115 grams +/- 10

Heavy Duty Covers = 143 grams +/- 10

Tear Strip Cover = 170 grams +/- 10

Brimful Capacity =

3.4 Gallons +/- .1 gallon

435 Fluid Ounces +/- 15 fl.oz.

3 Gallon Pail Dimensions

Height without Cover:

9.650 - 9.800 inches

Height with Cover:

9.750 - 9.900 inches

Top Diameter:

11.000 inches

Bottom Diameter:

10.125 inches

Nominal Wall Thickness:

.065 inches

Child Warning Labels are not required in California but are available at an additional charge. Handles or Bails are also available at an additional charge.

Material Used:

Virgin High Density Polyethylene

Available in:

Natural or White
Colors Available in
Truckload Quantities

Meets the following Regulations:

All materials used in these HDPE Pails and covers meet the requirements of Food Additive Regulation 21CFR177.1520.

These pails and covers are suitable for holding all types of food products.

Dairy Certification:

Container Supply is a certified I.M.S. single service container manufacturer.

Pallet pack Information:

Our Standard Pallet Pack Contains 400 - 3 gallon pails.

All Pallets are covered in a polyethylene shrink bag . Each pallet has a tag which identifies the pail inside and when it was manufactured.

Regular Covers come 180 per carton.

Heavy Duty Covers come 144 per carton.

Tear Strip Covers come 76 per carton